



Tyre diameter
 1.200 - 2.390 mm
 47" - 94"

Lift capacity
 1.200 kg
 2.646 lbs

Ideal for:
 Tyre Service Providers
 Farmers / AGRO Workshops
 Tyre Manufacturers / Retreaders
 Tyre Distributors / Dealers
 OEM assembly lines

**Easy
 Gripper
 Loader**

**Save
 time
 Improve
 safety**



Handling AGRO and EM/OTR tyres and wheels with front loader

- Secure and firm 3-point grip
- Improves the ergonomic working environment
- Simplifies mounting and dismounting of tyres and wheels
- Easy to adjust tyres and wheels in relation to hubs and bolts
- With Flat Top Arm as standard for limited tyre clearance



Experts in Tyre Handling Equipment



Improve safety and efficiency

The Easy Gripper Loader makes it safe and easy to handle AGRO and EM/OTR tyres and wheels. It eliminates the need for heavy manual labour such as lifting, pulling and pushing, thereby reducing the risk of both workplace accidents and strain injuries.

The Easy Gripper Loader is a budget-friendly alternative to our more advanced Easy Grippers – without compromising on safety or efficiency.

Capability

The Easy Gripper Loader has a gripping range from Ø1.200 - 2.390 mm and a lifting capacity of 1.200 kg at a CoG of 500 mm.



Mobile Tyre Service

When mounted on a telehandler or front loader, the Easy Gripper Loader allows a single operator to carry out tyre service on-site - even in rough or uneven terrain.

Simplifies Mount/Dismount

The integrated +/-25° manual controlled rotation together with the tilt delivered by the carrier simplifies alignment of tyre or wheel with hub or bolts.



Efficient logistics

The Easy Gripper Loader handles tyres and wheels both vertically and horizontally, enabling fast loading and unloading as well as optimisation of storage options.

Quick connection and disconnection

The Easy Gripper Loader can be quickly connected to and disconnected from the carrier vehicle.





Tyre Handling in Any Terrain

The Easy Gripper Loader is especially suitable for tyre handling in areas with unpaved surfaces or directly in the remote field.

Interchangeable Gripper Arm Sets

The gripper arms are supplied as standard in two different set sizes, covering the following gripping diameters:

- 1.200 - 1.800 mm (47 - 71") - short gripper arms
- 1.790 - 2.390 mm (70 - 94") - long gripper arms

A gripper arm set is supplied with a flat top arm, which makes it possible to grip a wheel when, for example, there is limited space between the tyre and the mudguard.

Standard included

The Easy Gripper Loader comes standard with a hydraulically controlled gripping function, manual $\pm 25^\circ$ rotation, a set of gripper arms with flat top arm in optional sizes, and is prepared for mounting on a standard ISO/FEM/ITA class 2 fork carriage.

Optional Accessories/customisation

- Quick coupler attachment system for JCB, Manitou, etc.
- Interface for mounting on standard class 3 fork carriage
- Customisation on request

Advantages of the Easy Gripper Loader

- Safety & Ergonomics
- Efficient and flexible tyre and wheel handling
- Efficient Logistics
- Compact and budget-friendly alternative



Quick manual adjustment of gripping diameter



Quick manual adjustment of gripping diameter

Technical Specifications

| | |
|--------------------------------------|---|
| Weight incl. Short Gripping Arm Set: | 230 kg (507 lbs) |
| Weight incl. Long Gripping Arm Set: | 250 kg (551 lbs) |
| Lifting capacity: | 1.200 kg (2.646 lbs) at C from B 500 mm (19.7") |
| Tyre diameter: | 1.200 - 2.390 mm (47.2 - 94.1") |
| Gripping length: | 600 mm (23.6") |

Technical Requirements

| | |
|-------------------|---|
| Attachment: | Standard: FEM/ISO/ITA class 2 fork carriage Specific quick coupler: on request |
| Hydraulic supply: | 1 double acting circuit (A+B port) |
| Pressure min-max: | 110 - 250 bar (1.596 - 3.626 psi) |
| Return pressure: | max. 10 bar (145 psi) |
| Flow: | max. 40 l/min. (11 gal/min.) |

- A** CoG Gripper = 160 mm (6.3")
- B** Face of Gripper = 250 mm (9.8")
- C** CoG Load = 750 mm (29.5")
- D** Length = 840 mm (33.1")

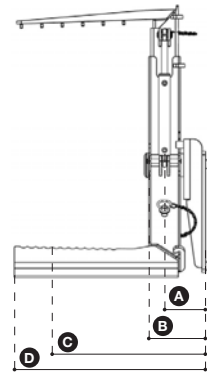

Interchangeable Gripper Arm Sets:

Short gripping arm set:

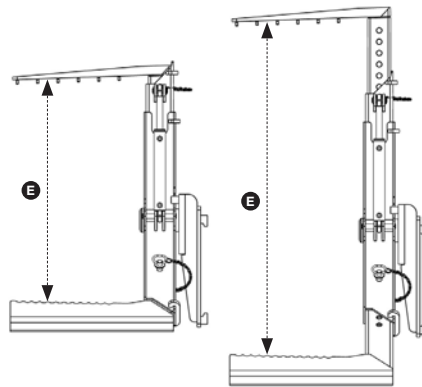

Long gripping arm set:

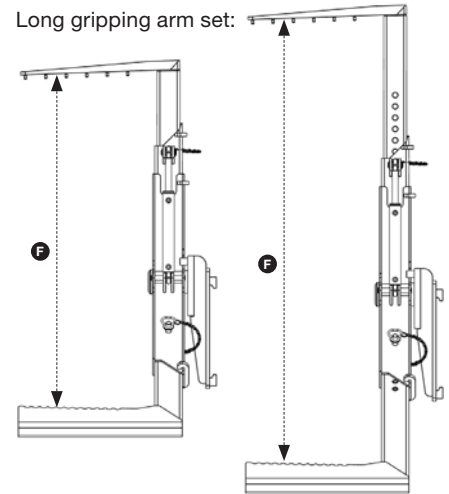

Gripping diameters:

- E** 1.200 - 1.800 mm (47.2 - 70.9")
- F** 1.790 - 2.390 mm (70.5 - 94.1")

Authorized Dealer

JET/ASY/COMPIL/LODEN/HEB/2.02/2026



+45 72 344 344
info@justeasytools.dk
www.justeasytools.com
VAT no.: DK33644809

Just Easy Tools ApS
Nybovej 33
7500 Holstebro
Denmark