



Ideal for:  
Mining  
Civil Construction

# Easy Gripper Cassette Handler

Lift  
capacity  
1.400 kg  
3.086 lbs



Patent Pending

## Professional cassette handling implements to suit all OEM cable bolting mining equipment

- Secure and firm 3-point grip of Cassette
- Hydraulic 90° tilt, horizontal to vertical
- Hydraulic  $\pm 25^\circ$  rotation
- Hydraulic locking with load locking valve
- Improve the ergonomic working environment
- Improves safety and efficiency
- Eliminates heavy lifts

Improve  
**Safety  
&  
Time**



Experts in Tyre Handling Equipment



# Improve safety and efficiency

The Easy Gripper Cassette Handler improves safety and efficiency. It saves time, and it significantly reduces risks for the operators when removing or re-loading the cassette, making the Easy Gripper Cassette Handler the correct tool for the task.

The compact design of the Easy Gripper Cassette Handler makes it easy to maneuver in restricted work environments together with the integrated hydraulic rotation function allowing a safe and efficient mounting process for stud hole alignment.

---

## Capability

The Easy Gripper Cassette Handler has a lifting capacity of 1.400 kg (3.086 lbs) at a CoG of 200 mm (7,9") from cassette brackets.

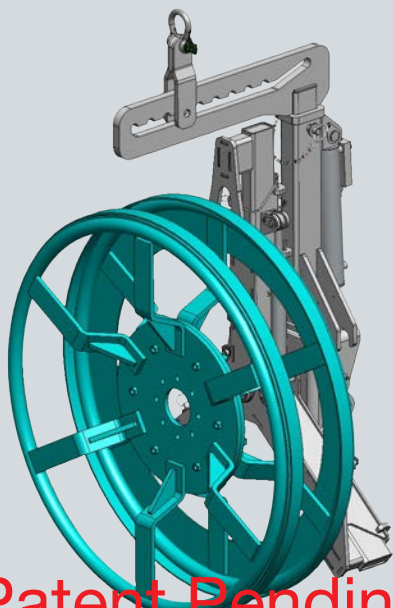

### Crane hook attachment

The Easy Gripper Cassette Handler is designed for use with truck cranes, workshop cranes and overhead cranes and is as standard delivered for hook attachment.

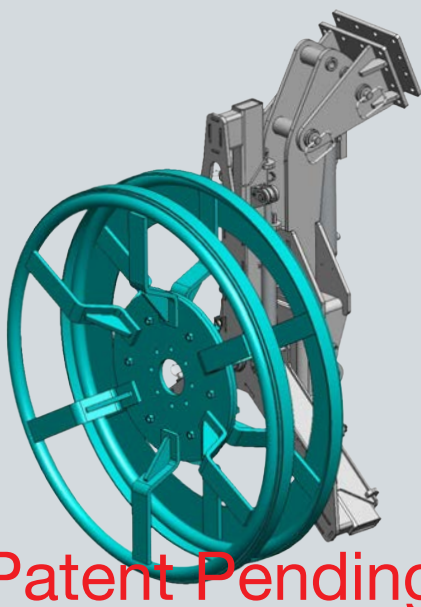

### Crane insert attachment

Alternatively the Easy Gripper Cassette Handler can be mounted in the end of the crane boom by using a crane specific insert.



Patent Pending

## Standard included

The Easy Gripper Cassette Handler comes as standard with:

- Hydraulic controlled locking function
- Hydraulic controlled 90° tilt
- Hydraulic controlled  $\pm 25^\circ$  rotation
- One Balance Lifting Bracket
- One Lifting Bracket for hook attachment
- Three Cassette Gripping Arms
- One set of 3 Cassette Brackets (to be welded on the cassette housing)

## Optional

- Extra Cassette Brackets in sets of 3 on request
- Crane Insert attachment
- Customization on request

## Optional tyre handler

Its easy to convert the Easy Gripper Cassette Handler into an Tyre Handler simply by replacing the three “Cassette Gripping Arms” and inserting another “Balance Lifting Bracket” and a “Connection Rod” between the “Balance Lifting Bracket” and the gripper part.

As standard the “Tyre Handling Gripping Arms” can be delivered in two different set sizes, covering the following gripping diameters:

- 1.200 - 1.800 mm (47 - 71”) - short gripper arms
- 1.790 - 2.390 mm (70 - 94”) - long gripper arms

The Tyre Handling Gripper Arm Set includes a flat top arm, which makes it possible to grip a wheel when, for example, there is limited space between the tyre and the mudguard.

The “Connection Rod” to be inserted between the “Balance Lifting Bracket” and the gripper part can as standard be delivered in three different lengths - 700 mm (28”), 1.000 mm (39”) and 2.300 mm (91”).

### Technical Specifications

Weight - hook attachment:	330 kg (728 lbs)
Weight - insert attachment:	375 kg (827 lbs)
Lifting capacity:	
As Cassette Handler at a CoG of 200 mm from face of lifting brackets:	1.400 kg (3.086 lbs)
As Tyre Handler at a CoG of 500 mm from face of Gripper:	1.200 kg (2.646 lbs)

### Hydraulic Requirements

Standard:	1 hydraulic circuit at the end of the crane boom (P+T port)
Alternatively:	2 or 3 hydraulic connections (A+B port)

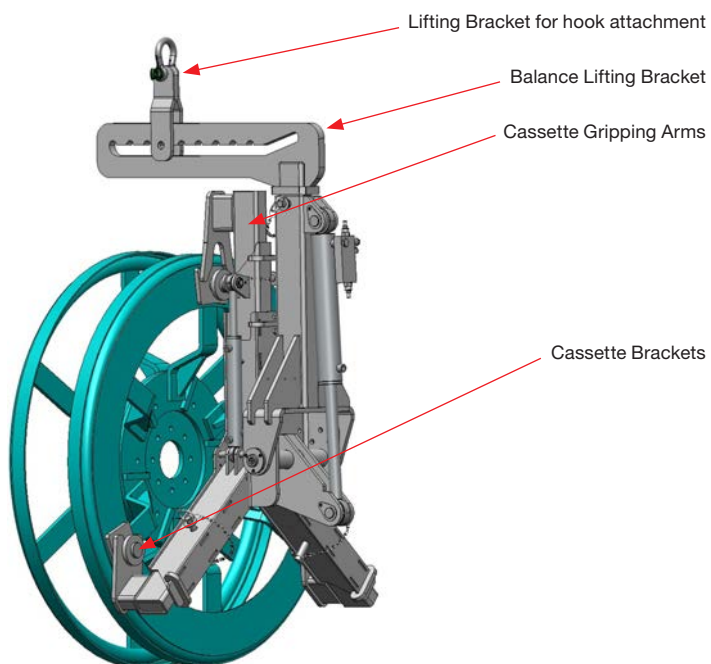

Patent Pending

Authorized Dealer

JET/AS/OPPERKASSETT/HANDLER - REV 1.0.02.2016



+45 72 344 344  
info@justeasytools.dk  
www.justeasytools.com  
VAT no.: DK33644809

Just Easy Tools ApS  
Nybovej 33  
7500 Holstebro  
Denmark