

Ideal for:  
Farmers / AGRO Workshops / OEM  
Tyre Manufacturers / Retreaders  
Tyre Distributors / Dealers  
Tyre Service  
Ports

Easy  
**Gripper**  
2160

Tyre  
diameter  
700 - 2.160 mm  
28 - 85"

Lift  
capacity  
1.000 kg  
2.200 lbs

Save  
**time**  
Improve  
safety



## Professional tools for handling of AGRO tyres and small OTR

- Unique 3-point grip
- Precise rotation +/-25°
- 90° tilt, horizontal to vertical
- Integrated camera system for optimal view
- Prevent damage to tyres, rims & equipment
- Tools for safe handling of tyre rings
- Easy hook on/off attachment

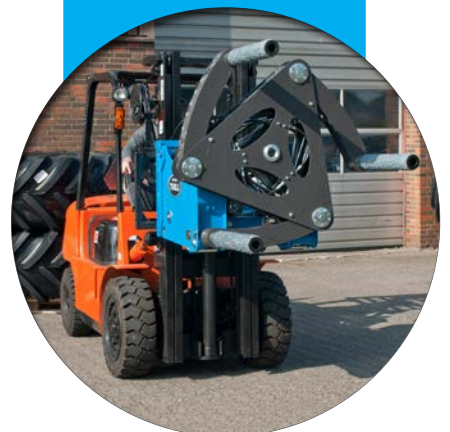

Experts in Tyre Handling Equipment



# Easy Gripper

The Easy Gripper product range is designed to help professional tyre technicians in a multitude of conditions and situations. Implementing The Easy Gripper makes tyre handling faster and safer, while preventing damages to tyres, rims and equipment.

## Capability

With a gripping range of Ø700 - 2.160 mm (28 - 85") and a lifting capacity of 1 ton (2.200 lbs) at a CoG of 500 mm (20") from face of gripper, the Easy Gripper 2160 is developed to handle AGRO and light OTR tyres. On request the gripping diameter can be extended to Ø2.400 mm (94") to handle even the biggest AGRO tyres.



## Manufacturers / dealers

Optimized tyre logistics - stack and store tyres and wheels both horizontally and vertically at workshops and warehouse areas. Fast and safe loading and unloading.

## Agriculture

Safe and efficient mount and demount of large AGRO tyres with no damages of rims and equipment. Minimize tyre wear and optimize ground pressure, helping protect crops.



## Ports

Reduces the down time and improves the safety for the tyre technicians while handling tyres and wheels on Straddle Carriers, Reach Stackers, AGVs and RTG cranes.



## Breakdown service

Mounted on front loaders, telehandlers or truck cranes you get a perfect and safe solution to provide tyre service in any environment with just one or two operators ... faster than usually.



## Forklifts



The Easy Gripper 2160 with the 90° tilt module is ideal for use on forklifts.

## Front loaders and telehandlers



The Easy Gripper 2160 Compact without the tilt module is a good choice depending on the tilt provided by the carrier.

## Truck cranes



By use of our Crane Module the Easy Gripper 2160 Compact also fit with almost any truck crane system.



## Standard features

### Unique and safe 3-point grip

Prevents accidents.  
Prevents deformation of tyres.  
Prevents damages to tyres, rims and equipment.

### Integrated camera system for optimal view

With automatic IR function in insufficient lighting conditions.

### Precise rotation +/-25°

### 90° tilt, horizontal to vertical

### Quick Shift Module

A mandatory and integrated part of the Easy Gripper 2160. It is mounted on the forklift, and the Easy Gripper is then hooked on to this module. Makes hook on/off easy.

## Optional accessories

### Fork Module

The Fork Module is designed to be hooked on to the Quick Shift Module and makes quick shift between Gripper and forks easy.

### Hydraulic Multi Connection

To optimize quick shift of the hydraulic hoses in less than a minute.

### Easy shift of gripping pipes for various purposes

Telescopic pipes for long reach, to provide room for the tyre fitter and for dual tyre handling.  
Flat top pipe for limited clearance.

### Ring Handling Tools

Enables the tyre fitter to handle Locking Rings, O-Rings, Side Rings and Bead Seat Bands in a safe and secure manner.

### RIM Handling Tools

The RIM Handling tools are yet a safety and efficiency add-on to the Easy Gripper program and improve the handling of OTR rims.

### Customization on request



Integrated camera system for optimal view



Unique and safe 3-point grip



Tools for safe handling of tyre rings

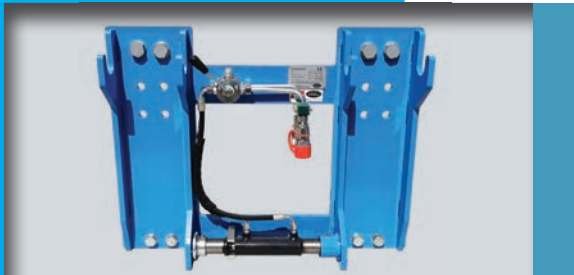

Quick Shift Module - screw coupling

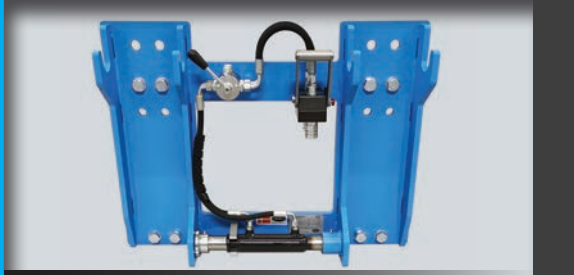

Quick Shift Module - hydraulic multi connection

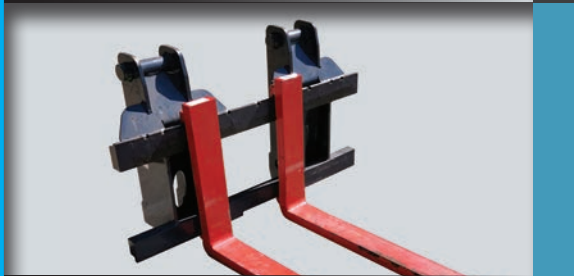

Fork Module



Flat top arm for limited tyre clearance



Telescopic pipes for long reach



Safe handling of rims

### Technical Specifications:

Weight:	Gripper = 550 kg (1,212.6 lbs)
	Quick Shift Module = 75 kg (165.4 lbs)
Lifting capacity:	1.000 kg (2.200 lbs) at <b>C</b> from <b>B</b> 500 mm (19.7")
	645 kg (1.422 lbs) at <b>D</b> from <b>B</b> 775 mm (30.5")
Tyre diameter:	700 - 2.160 mm (27.6 - 85.0")
Standard pipes:	Ø121 x 600 mm (4.8 x 23.6")
Telescopic pipes:	Ø133.5 x 600 -> 875 mm (5.3 x 23.6 -> 34.5")

- A** CoG Gripper = 765 mm (30.1")
- B** Face of Gripper = 980 mm (38.6")
- C** CoG Load1 = 1.480mm (58.3")
- D** CoG Load2 = 1.755 mm (69.1")

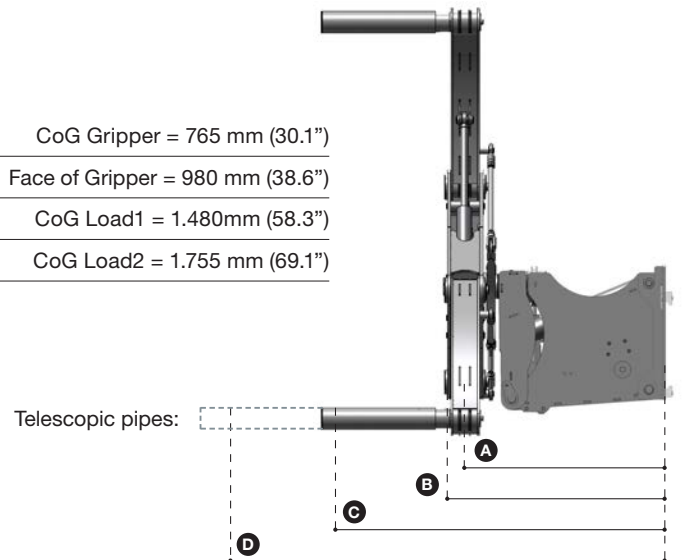

### Technical Requirements:

Lifting capacity:	Minimum 2.5 ton depending on carrier
Attachment:	ISO/FEM/ITA Class 2 or 3 / Loader specific
Electrical supply:	12V or 24V / min 10A
Hydraulic supply:	1 double acting circuit (A+B port)
Pressure min-max:	150 - 250 bar (2.175 - 3.626 psi)
Return pressure:	max. 10 bar (145 psi)
Flow:	max. 50 l/min. (13 gal/min.)

Authorized Dealer



+45 72 344 344  
 info@justeasytools.dk  
 www.justeasytools.com  
 VAT no.: DK33644809

Just Easy Tools ApS  
 Nybovej 33  
 7500 Holstebro  
 Denmark